

MAP Precision Attenuator



For stand-alone applications, the MAP Precision Attenuator may be used as a benchtop

Key Features

- Low insertion loss (IL) ≤ 1.5 dB
- Low polarization dependent loss (PDL) 0.05 dB
- Wide wavelength range
- High return loss (RL) ≥ 60 dB

Applications

- Dense wavelength division multiplexing (DWDM) channel equalization (up to 128 channel /controller address)
- Amplifier characterization
- Bit error rate (BER) testing
- Precise optical power control (± 0.01 dB)
- Loss simulation in DWDM fiber links
- Receiver and transmitter testing

The Multiple Application Platform (MAP) Precision Attenuator is a high resolution, wide wavelength range attenuator used in applications such as analog systems and high bit-rate digital systems. The attenuator is built on proven industry leading technology for maximum reliability and performance.

Many configurations are available: single or dual device per single width cassette, single-mode (SM) or multimode (MM) fiber, four standard connector types, and tap option or in-line power monitor feature. The power control option can function as an in-line power monitor.

Safety Information

- This cassette, when installed in a MAP chassis, complies to CE requirements plus UL3101-1 and CAN/CSA-C22.2 No. 1010.1

Continued**Application: Controlling Output Power**

One of the primary applications of an attenuator is to create a precise signal of known output power. With the MAP Precision Attenuator, three options are possible:

- A standard attenuator. To control output power, measurement of the input power is required prior to testing. Output power is externally calculated based on the set attenuation. Figure (a) shows a standard attenuator.
- A standard output tap. Calibration of the output power is achieved through use of an external power meter and calibration of the tap path loss. Adjustments for changes in input power require external adjustments of the attenuator. Figure (b) shows the implementation of the standard output tap.
- An internal in-line power monitor. Output powers can be set directly with internal calibration and monitoring compensating for input power and path losses. In addition, the unit may be set into a closed-loop mode where output power is dynamically controlled. Figure (c) shows the internal in-line power monitor.

Figure 1: Optical Configuration of the Attenuator Cassette

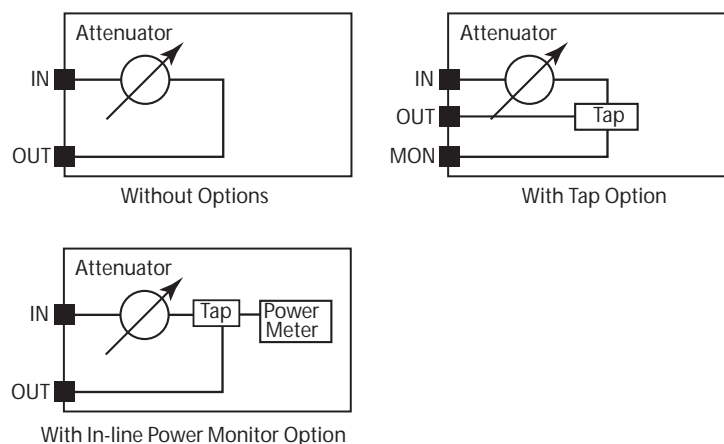

3

Specifications

Parameter	Single-mode fiber (SMF) without Power Monitor	Single-mode fiber (SMF) with Power Monitor	Multimode fiber (MMF) without Power Monitor	Multimode fiber (MMF) with Power Monitor
Wavelength range	1260 to 1650 nm	1260 to 1650 nm	750 to 1350 nm	750 to 1350 nm
Insertion loss (IL) ^{1,2,3} at minimum attenuation	≤ 1.5 dB ⁴	≤ 2.2 dB	≤ 2.2 dB ⁴	≤ 3.2 dB
Attenuation range	60 dB	60 dB	45 dB	45 dB
Attenuation repeatability ^{3,5}	± 0.01 dB	± 0.01 dB	0.01 dB	0.01 dB
Attenuation accuracy ^{3,6}	± 0.1 dB	± 0.1 dB	± 0.1 dB	± 0.1 dB
Attenuation slew rate (nominal)	>10 dB/s typical	>10 dB/s typical	> 7 dB/s typical	> 7 dB/s typical
Attenuation setting resolution	0.001 dB	0.001 dB	0.001 dB	0.001 dB
Maximum input power	23 dBm	23 dBm	23 dBm	23 dBm
Polarization dependent loss (PDL) ^{3,7}	≤ 0.05 dB ⁴	≤ 0.15 dB	N/A	N/A
Return loss (RL) (APC and PC connector) ^{4,8}	> 60/45 dB	> 60/45 dB	> 35/30 dB	> 35/30 dB
Closed-loop output power range (in-line power monitor option)	N/A	-49 to 11 dBm at 1310/1550 ± 15 nm	N/A	-40 to 5 dBm at 850/1310 ± 15 nm
Relative power meter uncertainty ^{3,5,9,10}	N/A	± 0.03 dB	N/A	± 0.03 dB
Power setting repeatability ^{5,9}	N/A	± 0.015 dB	N/A	± 0.015 dB
Power setting resolution	N/A	0.001 dBm	N/A	0.001 dBm
Shutter isolation	> 100 dB			
Calibration period	2 years			
Warm-up time	30 minutes			
Operating temperature	0 to 50 °C			
Storage temperature	- 30 to 60 °C			
Operating humidity	< 90 % at 23°C, < 20 % at 50 °C (relative, non-condensing)			
Dimensions (W x H x D)	4.06 x 13.24 x 39.5 cm			
Weight	1.1 kg (single) /1.3 kg (dual)			

- At 1310 ± 15 and 1550 ± 15 nm for SM unit and at 850 ± 15 and 1310 ± 15 for MM unit.
- Including one mated pair of connectors.
- At 23 ± 5 °C.
- Not including tap coupler loss, if installed.
- Constant wavelength, constant temperature, constant state of polarization.
- Maximum specification at 1310 ± 15 and 1550 ± 15 nm for SM unit and at 850 ± 15 and 1310 ± 15 for MM unit. Outside these wavelength ranges, the typical accuracy is the greater of ± 0.1 dB or ± 0.003 dB/dB.
- At 1310 ± 15 and 1550 ± 15 nm.
- At 1550 ± 15 nm for SMF and 1310 ± 15 for MMF.
- Over output power range.
- Add 0.01 dB/dBm for output power below - 45 dBm at 1310 and 1550 nm and output power below -40 dBm at 850 nm.

Ordering Information

For more information on this or other products and their availability, please contact your local JDSU account manager or JDSU directly at 1-800-498-JDSU (5378) in North America and +800-5378-JDSU worldwide or via e-mail at customer.service@jdsu.com.

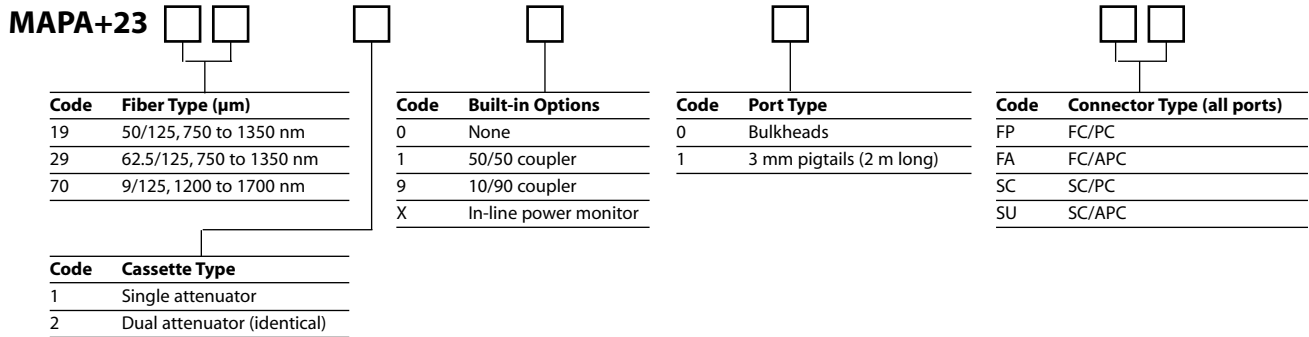
Sample: MAPA+2319101FA

If the configurations available do not meet your performance requirements, please contact our global sales and customer service team to discuss the potential for specialized solutions.

UNITRONICS, S.A.

Avda. de la Fuente Nueva, 5
 28709 San Sebastián
 de los Reyes - Madrid
 Telf.. 91 540 01 25
 Fax. 91 540 10 68

SMF is a registered trademark of Corning Incorporated.
 ST is a registered trademark of Lucent Technologies.
 UL is a registered trademark of Underwriters Laboratories Inc.

All statements, technical information and recommendations related to the products herein are based upon information believed to be reliable or accurate. However, the accuracy or completeness thereof is not guaranteed, and no responsibility is assumed for any inaccuracies. The user assumes all risks and liability whatsoever in connection with the use of a product or its application. JDSU reserves the right to change at any time without notice the design, specifications, function, fit or form of its products described herein, including withdrawal at any time of a product offered for sale herein. JDSU makes no representations that the products herein are free from any intellectual property claims of others. Please contact JDSU for more information. JDSU and the JDSU logo are trademarks of JDS Uniphase Corporation. Other trademarks are the property of their respective holders. ©2006 JDS Uniphase Corporation. All rights reserved. 10116397 Rev. 009 03/06 MAPPA.DS.TM.AE